

1) CONSTRUCTION:
 CONDUCTOR: 18 AWG 16/30 STRANDED TINNED COPPER
 INSULATION: POLYVINYLCHLORIDE, .016" NOM. WALL THICKNESS
 CABLE: (9) COLOR CODED SINGLES TWISTED TOGETHER WITH FILLER AND WRAPPED WITH A CLEAR POLYESTER BINDER TO FORM A CABLE CORE
 RIPCORD: INCLUDED UNDER JACKET FOR STRIPPING
 JACKET: POLYVINYLCHLORIDE, CHROME GRAY, .032" NOM. WALL THICKNESS.
 NOM. DIA. .045"
 .077"
 .284"
 OVER ALL CABLE DIAMETER .348"

2) PHYSICAL PROPERTIES:
 TEMPERATURE RATING, MAX. 105°C
 TEMPERATURE RATING, MIN. -20°C
 WT./M', NOM., NET. 83.1 LBS.
 JACKET IS UV RESISTANT

3) ELECTRICAL CHARACTERISTICS:
 CAPACITANCE, MUTUAL, NOM. 25 PF/FT.
 DIELECTRIC WITHSTANDING, MIN. 1500V RMS
 VOLTAGE RATING, MAX. 600V
 D.C. RESISTANCE, MAX. PER ASTM B286 7.15 Ω/1,000'

4) AGENCY APPROVALS:
 CSA AWM FT4
 UL AWM STYLE 2586 105C 600V

5) APPLICATION:
 INDUSTRIAL CONTROLS, MEDICAL ELECTRONICS AND OTHER APPLICATIONS WHERE A COMPACT 600V RATED CABLE IS REQUIRED. RoHS COMPLIANT MATERIALS.

6) PRINT:
 600V-TROL® E69976 **RU** AWM 2586 VW-1 -- CSA LL51726 AWM I/II A/B 105C 600V FT4 -- RoHS --
(LOT DESIGNATOR)

7) COLOR CODE:
 1. BLACK
 2. BROWN
 3. RED
 4. ORANGE
 5. YELLOW
 6. GREEN
 7. BLUE
 8. VIOLET
 9. GRAY

8) PACKAGING
 TO BE PACKAGED AS PER QWC'S STANDARD PACKAGING

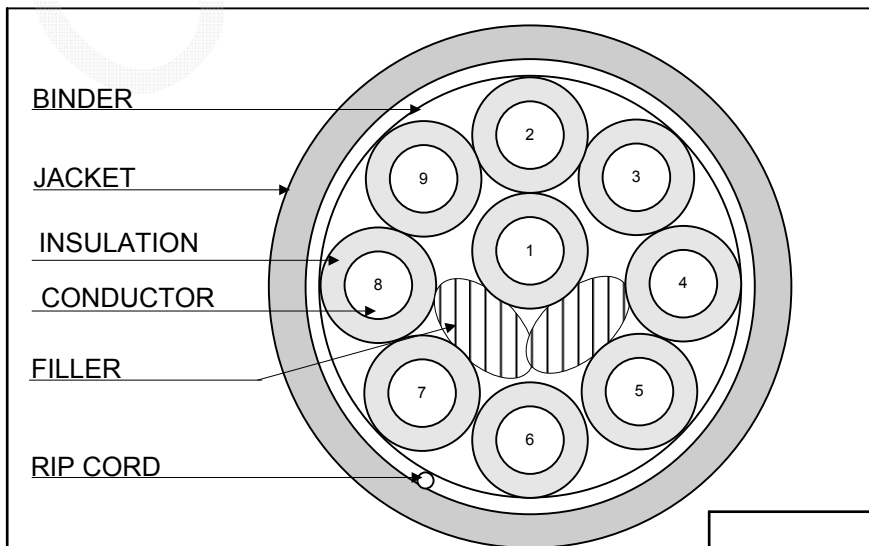

Created 05/25/04	DRAWN: SGH 06/04/18	
REV. 06	CHECKED: ZRS 06/04/18	
TITLE 600V-TROL® -- 9/C 18 AWG -- AWM 2586, CSA AWM FT4 CABLE		
QUABBIN P/N	0726	1 of 1

CUSTOMER APPROVAL:

DATE: